



FEDERATION INTERNATIONALE DE L'AUTOMOBILE

Groupe / Group

A

Homologation N°

A-5758

Extension N°

01/01 ET

FICHE D'EXTENSION D'HOMOLOGATION HOMOLOGATION EXTENSION FORM

Sauf indication contraire, toutes les dimensions sont indiquées en mm
Unless otherwise stated, all dimensions are specified in mm

Homologation valable à partir du
Homologation valid as from

01 MARS 2018

NOT VALID IN GROUP A / ONLY VALID IN GROUP N



ET Evolution du type / *Evolution of the type*

Toutes les informations enregistrées officiellement par le constructeur auprès de la FIA dans le cadre de la procédure d'homologation font également foi pour la conformité du véhicule
All information officially registered with the FIA by the manufacturer as part of the homologation procedure is equally authentic for the conformity of the vehicle

1. GENERALITES / GENERAL

101. CONSTRUCTEUR DU VEHICULE / MANUFACTURER OF THE VEHICLE

SUBARU CORPORATION

102. MODÈLE ET TYPE DE VEHICULE / MODEL AND TYPE OF THE VEHICLE

a) Modèle et type
Model and type

WRX STI 2015

A1) Voiture vue de 3/4 avant
Car seen from 3/4 front

A2) Voiture vue de 3/4 arrière
Car seen from 3/4 rear



3. MOTEUR / ENGINE

301. EMBLACEMENT ET POSITION DU MOTEUR / LOCATION AND POSITION OF THE ENGINE

a) Emplacement et orientation <i>Location and orientation</i>	FRONT		
b) Position <i>Position</i>	X =	79	± 5 mm
	Y =	420	± 5 mm
	Z =	55	± 3 mm
c) Inclinaison <i>Inclination</i>		5.8	deg ± 30'

Voir schéma / See scheme **III-A1)**

III-A1) POSITION DU MOTEUR / POSITION OF THE ENGINE

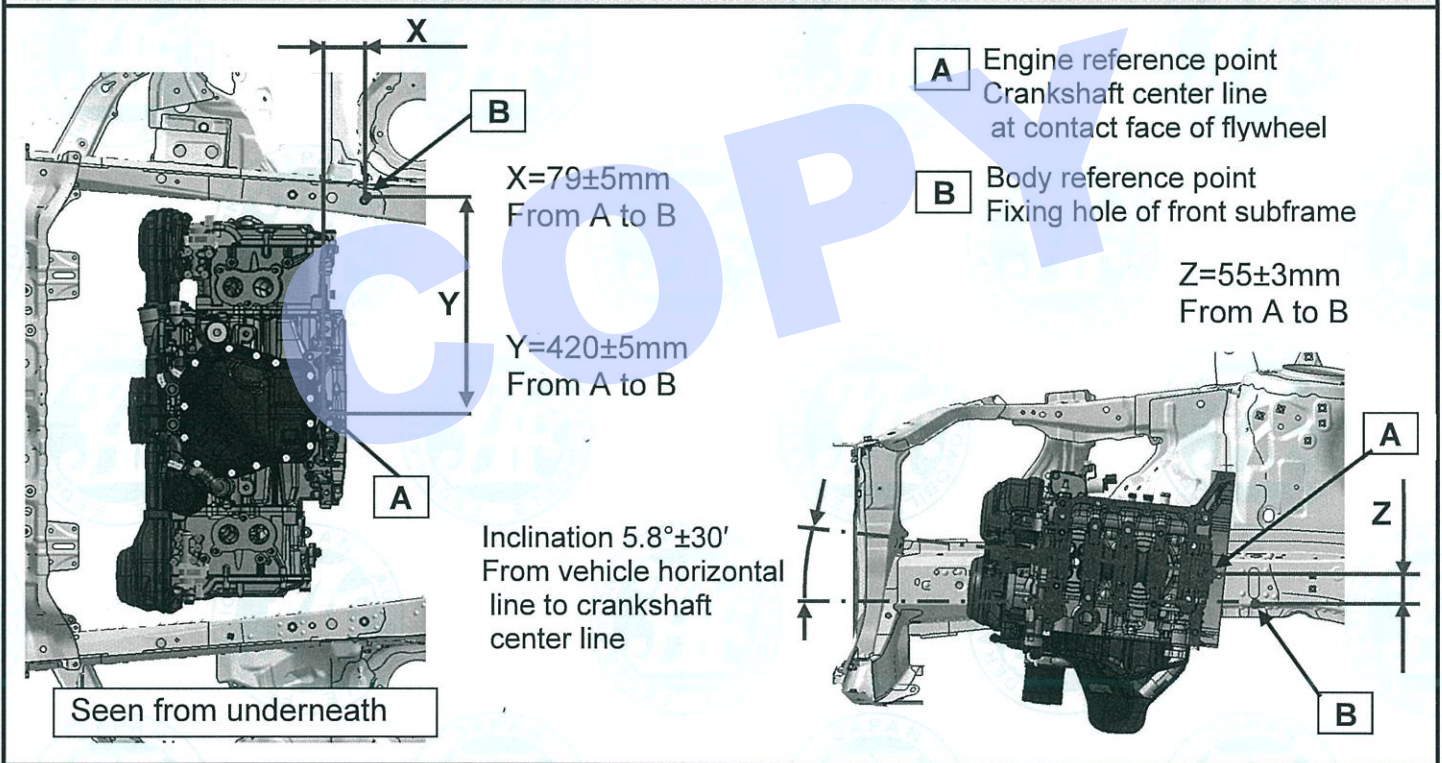

Marque
Make

SUBARU CORPORATION

Modèle
Model

WRX STI 2015

Homologation N°

A-5758

Extension N°

01/01 ET

C1-5) Moteur dans son compartiment
Engine in its compartment

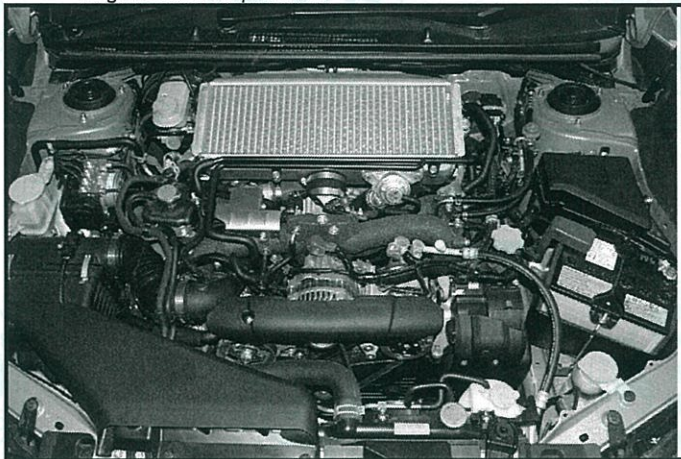

Changed design of stay for PCV pipe on intercooler

334. SURALIMENTATION / SUPERCHARGING

h) Refroidissement de l'air d'admission
Cooling of intake air

h1)

Oui / Yes



Non / No



Air/Air



Air/Eau
Air/Water



Simple-passe
Single-flow



Double-passe
Double-flow



h2) Système
System

h3) Diamètre de l'entrée d'air
Air inlet diameter

60 x 2

± 1mm

h4) Diamètre de la sortie d'air
Air outlet diameter

65

± 1mm

C15-8) Intercooler – dismounted

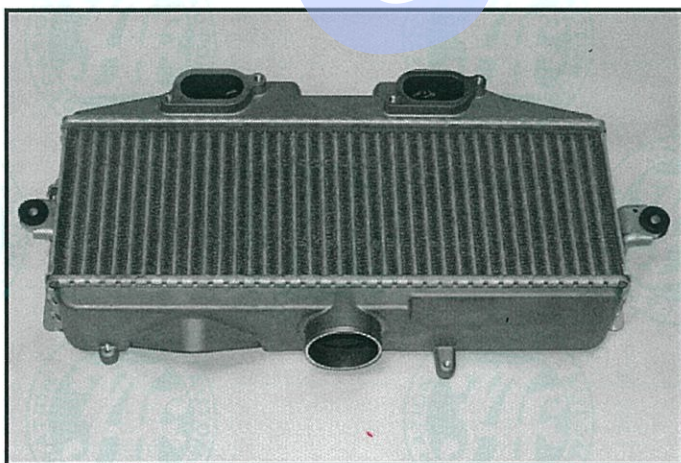

C15-9) Intercooler – mounted in its location

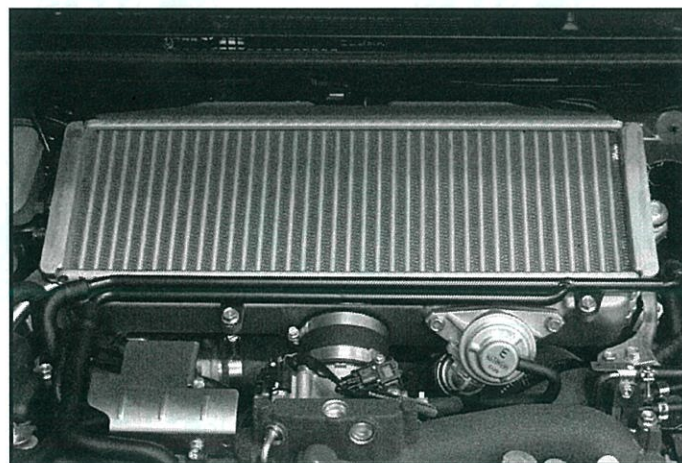

Marque
Make

SUBARU CORPORATION

Modèle
Model

WRX STI 2015

Homologation N°

A-5758

Extension N°

01/01 ET

**III-07) SYSTEME DE REFROIDISSEMENT DE L'INTERCOOLER
INTERCOOLER COOLING SYSTEM**

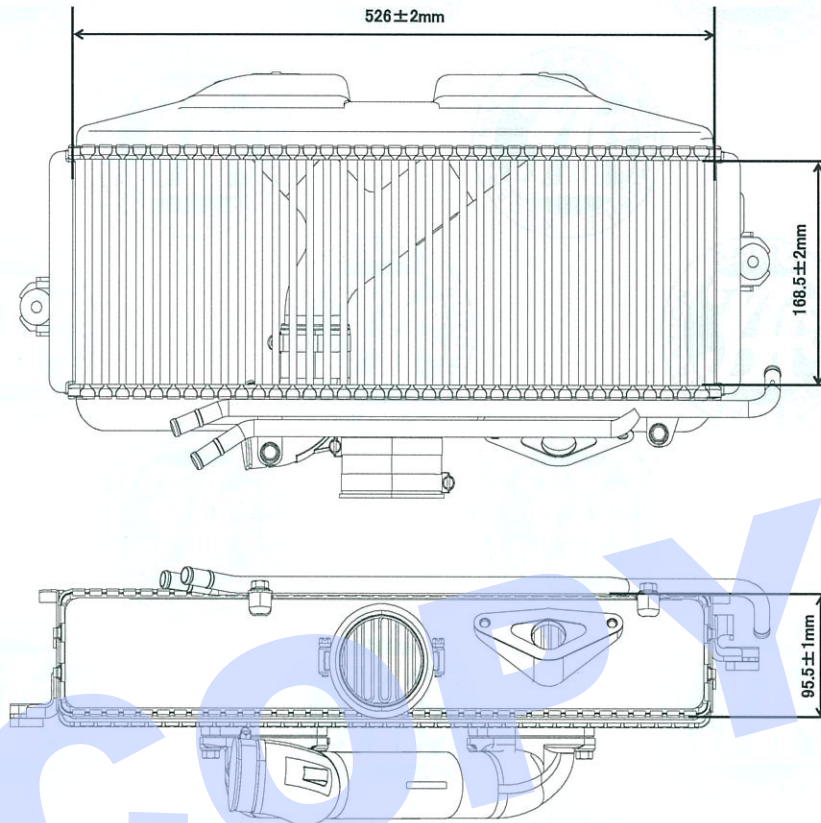

Marque
Make

SUBARU CORPORATION

Modèle
Model

WRX STI 2015

Homologation N°

A-5758

Extension N°

01/01 ET

7. ESSIEUX ET SUSPENSION / AXLES AND SUSPENSION

G1-1) Essieu avant complet assemblé - déposé
Complete **front** axle assembly - *dismounted*

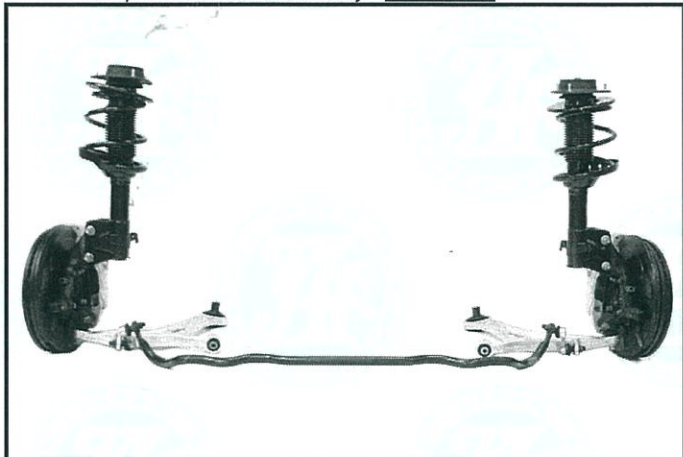

G1-2) Essieu avant complet assemblé - déposé
Complete **front** axle assembly - *dismounted*

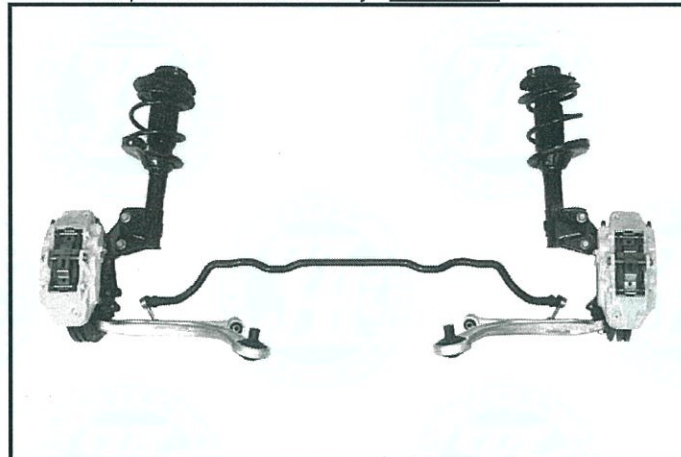

H1-1) Essieu arrière complet assemblé - déposé
Complete **rear** axle assembly - *dismounted*

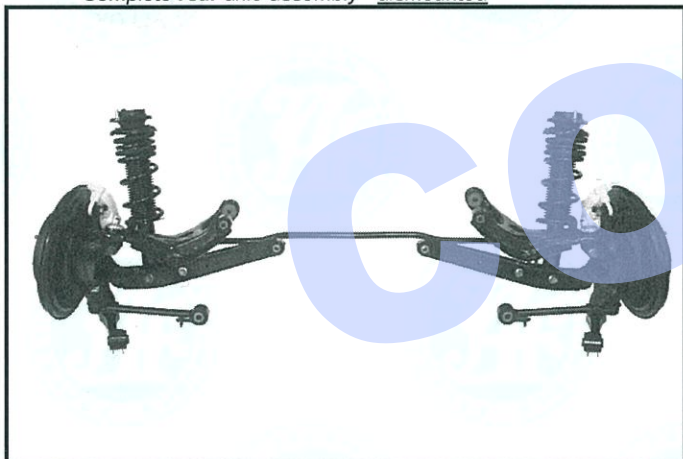

H1-2) Essieu arrière complet assemblé - déposé
Complete **rear** axle assembly - *dismounted*

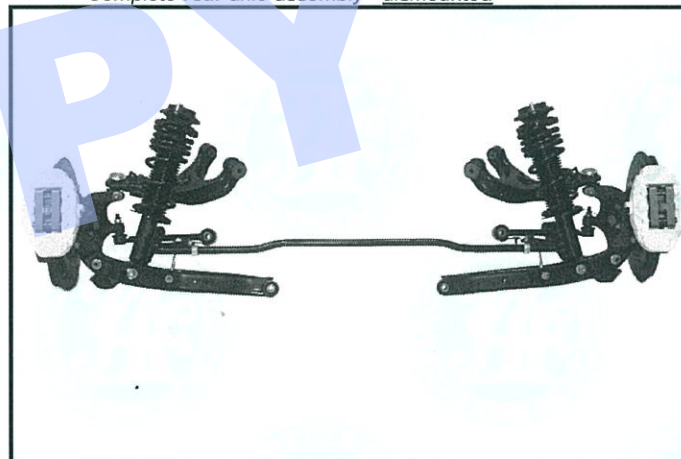

8. TRAIN ROULANT / RUNNING GEAR

801. ROUES / WHEELS

a) Diamètre
Diameter

AVANT / FRONT	ARRIERE / REAR
482.6 mm 19 inches	482.6 mm 19 inches

803. FREINS / BRAKES

e) Nombre de cylindres par roue
Number of cylinders per wheel

e1) Alésage
Bore

AVANT / FRONT	ARRIERE / REAR
6	2
2x38.0, 2x34.0 2x30.0 ± 0.1 mm	2x40.0 ± 0.1 mm

g) Freins à disques / Disc brakes

g1) Nombre de plaquettes par roue
Number of pads per wheel

g2) Nombre d'étriers par roue
Number of calipers per wheel

g3) Matériau des étriers
Caliper material

g4) Epaisseur du disque neuf
Thickness of new disc

g5) Diamètre extérieur du disque
External diameter of disc

g6) Diamètre extérieur de frottement des plaquettes
External diameter of pads'rubbing surface

g7) Diamètre intérieur de frottement des plaquettes
Internal diameter of pads'rubbing surface

g8) Longueur de friction hors-tout de chaque plaquette
Overall friction length of each pad

g9) Disques ventilés
Ventilated discs

Nombre de canaux de ventilation
Number of venting channels

AVANT / FRONT	ARRIERE / REAR
2	2
1	1
ALUMINIUM ALLOY	ALUMINIUM ALLOY
30.0 ±1.5 mm	20.0 ±1 mm
340.0 ±1.5 mm	326.0 ±1.5 mm
338.0 ±1.5 mm	322.8 ±1.5 mm
223.6 ±1.5 mm	217.4 ±1.5 mm
160.7 ±1.5 mm	99.7 ±1.5 mm
Oui/Yes <input checked="" type="checkbox"/> Non/No <input type="checkbox"/>	Oui/Yes <input checked="" type="checkbox"/> Non/No <input type="checkbox"/>
31	31

P10)



P11)

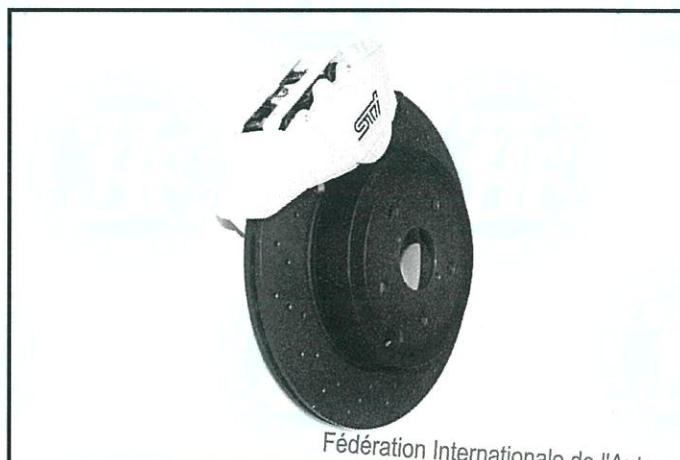

Marque
Make

SUBARU CORPORATION

Modèle
Model

WRX STI 2015

Homologation N°

A-5758

Extension N°

01/01 ET

9. CARROSSERIE - CHASSIS (COQUE) / BODYWORK - CHASSIS (BODYSHELL)

L1-1) Planche de bord
Dashboard



Fédération Internationale de l'Automobile
Chemin de Blandonnet, 2
CH-1215 GENEVE 15
Tél.: 41 22 544 44 00
Fax Sport: 41 22 544 44 50

Marque
Make

SUBARU CORPORATION

Modèle
Model

WRX STI 2015

Homologation N°

A-5758

Extension N°

01/01 ET

XIII-A1) MATERIAUX DES PANNEAUX DE CARROSSERIE / MATERIALS OF BODYWORK PANELS

MATERIAUX METALLIQUES / METALLIC MATERIALS

Numéro / Label	Pièce / Part	Matériau / Material
01	FRONT HOOD	ALUMINIUM ALLOY
02	FRONT FENDER	STEEL
03	FRONT & REAR DOOR	STEEL
04	REAR BOOT LID	STEEL

MATERIAUX PLASTIQUES / PLASTIC MATERIALS

Numéro / Label	Pièce / Part	Matériau / Material
05	ROOF MOULDING	PLASTIC
06	FRONT BUMPER	PLASTIC
07	HEAD LAMP	PLASTIC
08	FRONT FENDER GARNISH	PLASTIC
09	REAR BUMPER	PLASTIC
10	REAR BOOT GARNISH	PLASTIC
11	REAR SPOILER	PLASTIC
12	SIDE SPOILER	PLASTIC
13	REAR COMBI LAMP	PLASTIC
14	FRONT DOOR MOULDING	PLASTIC
15	REAR QUARTER MOULDING	PLASTIC
16	DOOR MIRROR	PLASTIC
17	DOOR HANDLE	PLASTIC
18	ROOF ANTENNA	PLASTIC
19	FRONT HOOD GRILL	PLASTIC

VITRAGES / GLAZING

Numéro / Label	Pièce / Part	Matériau / Material	Epaisseur min. / Min. thickness
21	WINDSCREEN	LAMINATED GLASS	4.3 mm
22	FRONT DOOR WINDOW	SAFETY GLASS	3.8 mm
23	REAR DOOR WINDOW	SAFETY GLASS	2.9 mm
24	FRONT QUARTER WINDOW	SAFETY GLASS	3.8 mm
25	REAR QUARTER WINDOW	SAFETY GLASS	2.9 mm
26	REAR WINDOW	SAFETY GLASS	2.9 mm

Fédération Internationale de l'Automobile
Chemin de Blandonnet, 2
CH-1215 GENEVE 15
Tél.: 41 22 544 44 00
Fax Sport: 41 22 544 44 50

DESSIN / DRAWING

